

Instructions for the QGY10P Oxygen Concentration Monitoring System



QGY10P

Contents

1. Safety Instructions	3
2. Overview	3
3. Main Components	4
4. Technical Parameter	4
5. Function Description	5
5.1 measuring principle	5
5.2 Heating strategy and sensor operating status	6
5.3 Display Function	7
5.4 Analog output	8
5.5 Alarm	9
5.6 MODBUS register parameters and description.....	10
6. Oxygen sensor structure.....	12
7. Installation and connection.....	12
7.1 Installation oxygen sensor	12
7.2 Controller installation	14
7.3 Connect.....	14
8. Dimension	16

1. Safety Instructions

To avoid causing safety accidents or causing property damage, please carefully read the following safety instructions:

- All operations (assembly, installation, maintenance, etc.) must be carried out by trained technical personnel.
- Please follow the operating instructions for correct wiring . The equipment is equipped with multiple terminal interfaces such as 24 V power supply, sensor access, analog output, 220V signal input, and safety circuit access. If the wiring is incorrect, it may cause equipment damage and even cause safety accidents.
- There is a risk of burning since the measuring cell works at an operating temperature of 800°C and other accessible parts can get very hot too (>60°C)
- Fall or shock can adversely affect the safety functions and lead to dangerous conditions. Such sensors must not be put into operation, even if the measuring cell does not exhibit any damage.
- Do not approach flammable and explosive gases during work.
- Do not immerse the sensor in liquids such as water and oil, otherwise the liquid may enter the sensor and cause damage.

2. Overview

The function of the QGY10P oxygen concentration monitoring system is to measure the residual oxygen content in the flue gas of natural gas, liquefied petroleum gas, and light oil burners. It can provide real-time feedback on the combustion status of the burner.

When the combustion is not sufficient and a large amount of harmful gases may be generated (preset by the system in advance), it can issue an alarm in a timely manner to cut off the safety circuit of the burner.

Note!

The flue gas analyzer measures the oxygen content of dry flue gas (without water vapor), while QGY10P measures the oxygen content of wet gas. The measured values of wet flue gas may be lower than those of dry flue gas, therefore conversion is necessary when conducting combustion analysis calculations

The conversion values are shown in Fig.1 (fuel is natural gas).

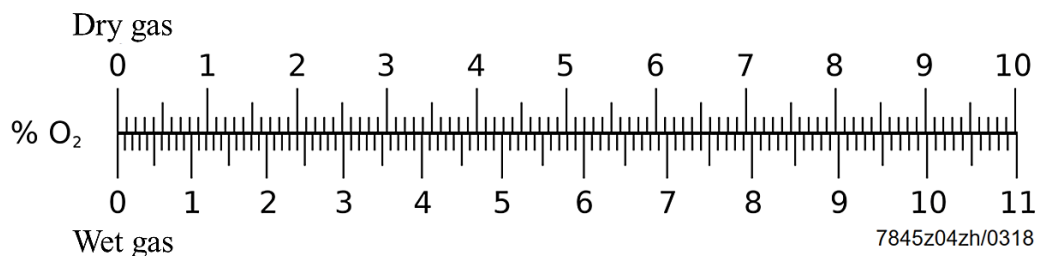





Fig.1 Conversion table for dry and wet gas values

3. Main Components

Picture	Name	Model
	Sensor	QGY10.000A8
	Controller	AGY10.000A8
	Flue gas collector	AGY20.120A/AGY20.220A
	Connector	A1B0923A

4. Technical Parameter

Project	Specification Requirements
Supply voltage	24 V DC
Power consumption	Maximum 30 W, typical 13 W
Start signal	220 V AC
Voltage analog quantity	2-10 V
Current analog quantity	4-20 mA The circuit requires an additional 24 V DC power supply
Protection grade	-Oxygen sensor: IP65 -Controller: IP20
Weight (excluding flue gas collector and cables)	301 g
Oxygen sensor controller connection cable	-4 core copper core cable -Minimum wire area 0.75mm ²
Measurement range	0.5 - 21%
Measurement accuracy	± 0.3%
Light-off time T ₉₀	≤60s
Permissible flue gas flow velocity	1-20m/s
Permissible fuel usage	Natural Gas, Liquefied Petroleum Gas, Light Oil
Permissible cable length for oxygen sensor controller connection	Wire diameter: 0.75 mm ² , with a maximum length of 4 m Wire diameter: 1.0 mm ² , with a maximum length of 5 m Wire diameter: 1.5 mm ² , with a maximum length of 8 m Wire diameter: 2.5 mm ² , with a maximum length of 13 m Wire diameter: 4.0 mm ² , with a maximum length of 20 m
Storage environment	Temperature: -20-60°C Humidity: < 95% R.H
Operating environment	Permissible flue gas temperature: 80-350°C * Sensor temperature : Before hexagon: -20-350°C Adapter tube: -20-180°C Hesmann joint: -20-60°C Controller temperature: -20-60°C Humidity: < 95 R.H
Installation height	Maximum altitude 2000 m

* This product is not recommended for use under flue gas temperatures below 80 °C, as smoke condensation can cause damage to the oxygen sensor and result in error. Therefore, it is necessary to choose a suitable installation location, such as upstream of the condenser.

5. Function Description

5.1 measuring principle

The lattice structure of yttrium stabilized zirconia (YSZ) has certain oxygen vacancies, which can conduct oxygen ions at high temperatures (above 350 °C). On this basis, if there is a difference in oxygen concentration on both sides, the side with high oxygen concentration will spontaneously diffuse towards the side with low oxygen concentration. At that time, ion migration will form in the zirconia conductor, forming a potential difference on both sides. As shown in Fig.2

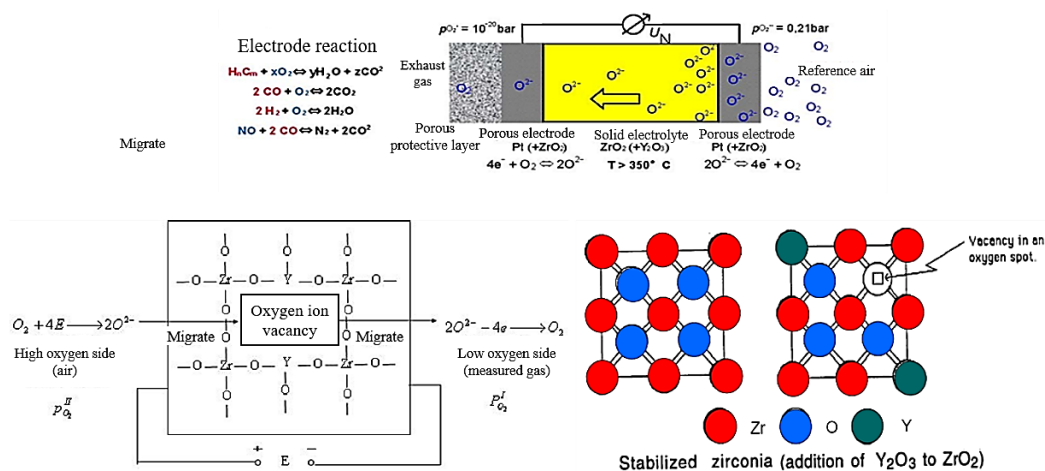

Fig.2 Conductive mechanism of zirconia

On the contrary, if a fixed voltage is applied on both sides of zirconia, the oxygen on one side will ionize into oxygen ions and move towards the other side under the driving force of the voltage, thus forming a current. The sensor structure design is shown in Fig.3(a). Oxygen diffuses to the cathode through a small hole or porous layer, while the amount of oxygen reached is significantly reduced due to the limitation of the hole. If a certain voltage is applied to the electrodes on both sides of zirconia can observe a phenomenon: As the applied voltage increases, the oxygen concentration near the cathode gradually decreases, that the potential difference formed due to the difference oxygen in oxygen concentration on both sides will increase. Until the oxygen concentration near the cathode is 0, even if the voltage continues to increase, the potential difference on both sides of zirconia will not increase. At this point, the corresponding current value is called saturation current

As shown in Fig.3(b), the saturation current at different oxygen concentrations is a fixed value, which is related to the structure of the sensor. For the same sensor, the saturation current and oxygen concentration follow a certain functional relationship.

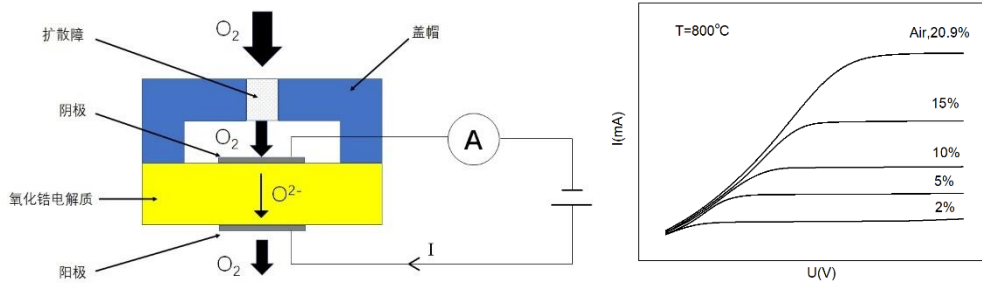

Fig.3 (a) Schematic diagram of ion flow oxygen sensor structure (b) Saturation current platform under different oxygen concentrations

For the porous layer intake ion flow oxygen sensor, the relationship between the saturation current of the sensor and oxygen concentration is shown in Fig.4.

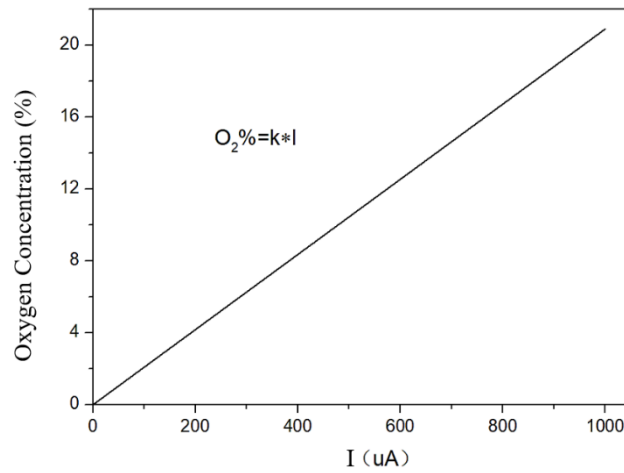

Fig4. The relationship between typical oxygen concentration and saturation current of oxygen sensors

The oxygen concentration and sensor signal current follow a linear function relationship, the formula is as follows:

$$O_2\% = k * I$$

Among them, $O_2\%$ represents the percentage of oxygen concentration, k represents a fixed constant related to the sensor structure, and I represents the sensor signal current.

5.2 Heating strategy and sensor operating status

The sensor uses an internal integrated heater to provide the temperature required for its operation. When a DC voltage is applied to both ends of the heater, the heater will consume a certain amount of power, and the values of the two are related. To protect the sensor and prevent component damage due to rapid heating, a heating strategy as shown in Fig.5 has been set.

The trend of the sensor signal over time is shown in Fig.5. Define T_1 as the time required for the sensor temperature and signal to reach basic stability. The sensor is defined as heating before T_1 . And after this, the signal is in a stable state.

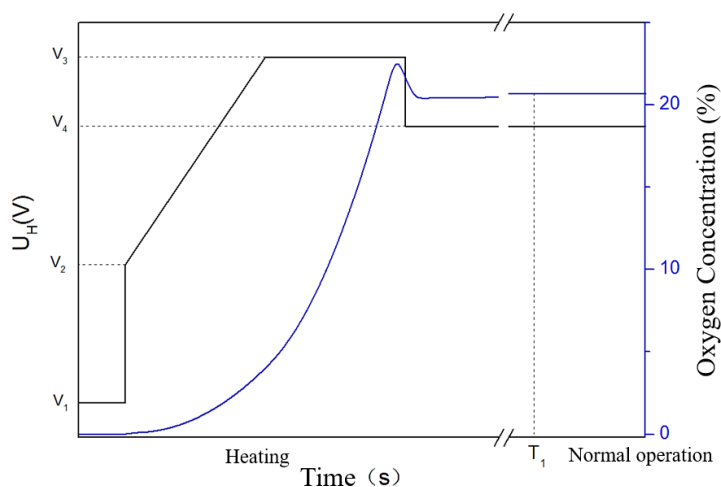

Fig.5 Heating strategy and oxygen concentration signal trend over time

5.3 Display Function

This oxygen monitoring system comes with a screen display function, which displays some important output parameters on the screen for easy judgment of combustion status. The content and meaning displayed on the screen are as follows:

Item	Show Content	Illustrate	Example
氧浓度 (Oxygen concentration)	Oxygen concentration value	Current position real-time oxygen concentration	
输出信号 U_0 (Output signal voltage)	Voltage analog value	Voltage analog quantity corresponding to oxygen concentration	
输出信号 I_0 (Output signal current)	Current analog value	Current analog quantity corresponding to oxygen concentration	
当前状态 (Current state)	待机(Standby) 加热中(Heating) 正常工作 (Normal operation)	Standby: Ready to enter work Heating: Oxygen sensor heating Normal operation: Output stable sampling signal	
报警状态 (Alarm status)	无、报警 (见章节 5.5) (None, alarm (See Chapter 5.5))	Trigger alarm	
上次报警 (Last alarm)	无、报警 (见章节 5.5) (None, alarm (See Chapter 5.5))	Display the last alarm status that occurred	

To assist with the screen display function, There are two indicator lights, green and red, on the side of the display screen. The status of the indicator light is explained as follows:

On light status	Corresponding working status
Green light flashing	Position in readiness
	Received start signal, oxygen sensor heating preparation enters working state
Green light always on	Normal operation
Red light always on	Oxygen sensor malfunction
Flashing red light	Alarm for low oxygen concentration in flue gas
Note: Only one color light comes on at a time	

5.4 Analog output

The AGY10.000A8 controller preset analog output port can output analog signals of 2-10V and 4-20mA in two specifications. Additionally, 4-20mA analog signals require an external 24V DC power supply. There is a logical correspondence between the analog signal and oxygen concentration, and the default logical correspondence at the factory is shown in Fig.6:

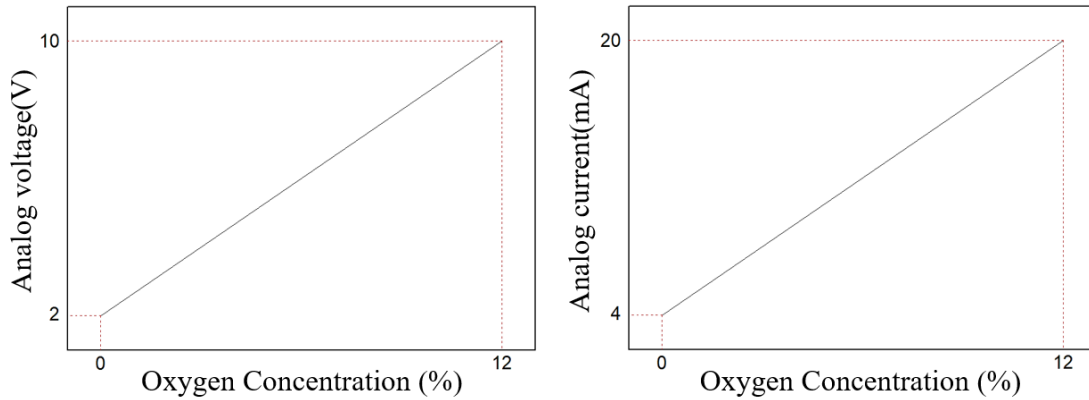

Fig.6 Relationship between oxygen concentration with (a) analog voltage (b) analog current output

Analog voltage output converted to oxygen concentration O_2 :

- 1) $0 \leq O_2 \leq 12\%$ $O_2 = (U_0 - 2) * 12/8$
- 2) $O_2 > 12\%$ $U_0 > 10.2V$, No conversion relationship with O_2
- 3) Fault is occurring $U_0 < 1V$, No conversion relationship with O_2

Analog current output converted to oxygen concentration O_2 :

- 1) $0 \leq O_2 \leq 12\%$ $O_2 = (I_0 - 4) * 12/16$
- 2) $O_2 > 12\%$ $I_0 > 20.5mA$, No conversion relationship with O_2
- 3) Fault is occurring $I_0 < 2mA$, No conversion relationship with O_2

The default relationship between the upper and lower limits of oxygen concentration to be monitored and the simulated amount can be preset. If the corresponding relationship between oxygen concentration and simulated quantity is set according to the following figure, the conversion relationship will change.

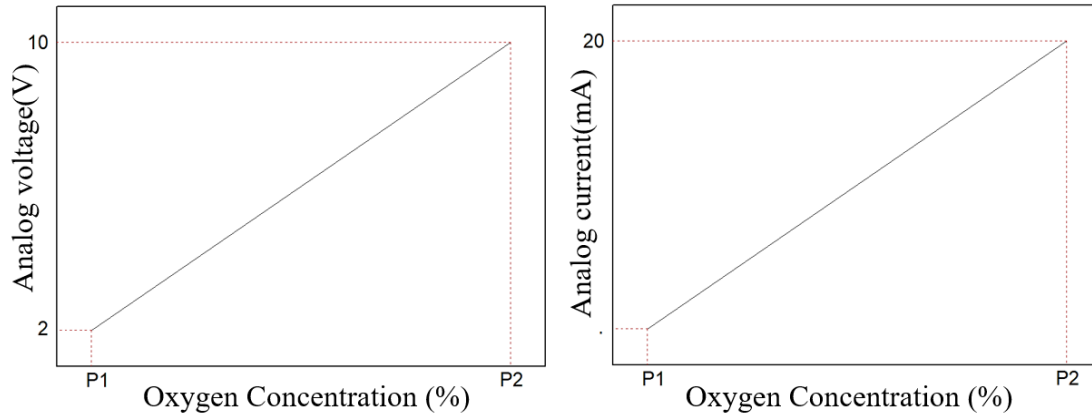

Fig.7 Relationship between oxygen concentration with (a) analog voltage (b) analog current output

Analog voltage output converted to oxygen concentration O_2 :

- 1) $P1\% \leq O_2 \leq P2\%$ $O_2 = (U_0 - 2) * (P2 - P1) / 8$
- 2) $O_2 > P2\%$ $U_0 > 10.2V$, No conversion relationship with O_2
- 3) Fault is occurring $U_0 < 1V$, No conversion relationship with O_2

Analog current output converted to oxygen concentration O_2 :

- 1) $P1\% \leq O_2 \leq P2\%$ $O_2 = (I_0 - 4) * (P2 - P1) / 16$
- 2) $O_2 > P2\%$ $I_0 > 20.5mA$, No conversion relationship with O_2
- 3) Fault is occurring $I_0 < 2mA$, No conversion relationship with O_2

5.5 Alarm

The oxygen sensor is mainly designed to monitor the combustion condition of the burner. When the oxygen concentration value in the measured flue gas is too low, it means that harmful gases may be generated. At this time, the detection system will issue an alarm and the normally closed contact will be disconnected. In addition, the oxygen sensor monitoring system also has a health diagnosis function for oxygen sensors. When the aging error of the oxygen sensor exceeds a reasonable range, an alarm will also be issued. The alarm code is as follows:

Alarm code	Alarm content	Trigger conditions
E01	Low oxygen alarm	The oxygen concentration in the flue gas is lower than the preset lower limit
E02	Heating open circuit	Oxygen sensor heating circuit open circuit
E03	Heating short circuit	Oxygen sensor heating circuit short circuit
E04	Signal open circuit	Oxygen sensor signal circuit open circuit
E05	Signal short circuit	Oxygen sensor signal circuit short circuit
E06	Aging alarm	Two consecutive start signal diagnoses within a cycle deviate from a reasonable range

5.6 MODBUS register parameters and description

MODBUS Hold Register Address

Item	Register address	Describe	Data type
Analog current output	0x009C(40156)	Unit mA, floating point type (float cdab)	Read only
Analog voltage output	0x009A(40154)	Unit V, floating point type (float cdab)	Read only
Oxygen concentration	0x0094(40148)	Oxygen concentration ,unit%, floating point type (float cdab) For example, if the oxygen concentration in normal temperature and pressure air is 20.7%, the floating-point type data read is 0.207	Read only
Address of this website	0x00AC(40172)	The effective value range is 1-31, unsigned integer, and the address depends on the setting of the hardware dial switch. The factory defaults to 1	Read only
Calendar, year/month	0x00AD(40173)	View: Calendar	Read only
Calendar, day/hour	0x00AE(40174)		Read only
Calendar, minutes/seconds/meaningless	0x00AF(40175)		Read only
Low oxygen alarm limit	0x0160(40352)	The valid value range is 0.00~1.00, with floating point type (float cdab). The default value is 0.03	Read and write
Lower limit of oxygen concentration	0x0162(40354)	The valid value range is 0~0.999, with a floating point type (float cdab). The default value is 0. It is permanently saved and is valid for power outage and restart	Read and write
Upper limit of oxygen concentration	0x0164(40356)	The valid value range is 0~0.999, with a floating point type (float cdab). The default value is 0.12, permanently saved, and valid for power outage and restart.	Read and write
485 Port Baud Rate Setting	0x017C(40380)	Viewing: Serial Port Settings	Read and write
Alarm Record 1-20: Year/Month	0x0180 (40381+3*N)	View: Calendar, N value range from 1 to 20, representing the nth alarm record	Read only
Alarm record 1-20: day/hour	0x0181 (40382+3*N)		Read only
Alarm record 1-20: minutes/seconds/record	0x0182 (40383+3*N)		Read only

Maintain register bit segment allocation

Item	Subitem	Bit segment	Illustrate
Calendar	Year/Month Holding Register	Month: Bit 0~7	Effective value range 1-12
		Year: Bit 8~15	Effective value range 0~99
	Day/Hour Holding Register	Hour: Bit 0~7	Effective value range 0~23
		Day: Bit 8~15	Effective value range 1~31
	Minute/second/meaningless (or record) holding register	No meaning/alarm record: Bit 0~3	Effective value range 0~6: 0 = No alarm 1 = Heating port short circuit alarm 2= Heating port open circuit alarm 3 = Sensor port short circuit alarm 4 = Sensor port open circuit alarm 5 = Aging alarm 6 = Oxygen concentration below lower limit alarm
		Minute: Bit 4~9	Effective value range 0~59
		second: Bit 10~15	Effective value range 0~59
Serial port	Serial Port Setting Holding Register	Serial baud rate setting: Bit 0~1	Effective interval 0~3: 0、2、3=9600 1=4800
		Serial port stop bit setting: Bit 2~3	Effective interval 0~3: 0~1=1 stop bit 2=2 stop bit 3=1.5 stop bits
		Serial port parity settings: Bit 4~5	Effective interval 0~3: 0、3= No parity 1= Odd parity check 2= even parity check
		Spare: Bit 6~15	Effective interval 0~1023: 0~1023= Meaningless

Default Setting

Item	Name	Default value
Logical Settings	Low oxygen alarm limit	3%
	Lower limit of oxygen concentration	0%
	Upper limit of oxygen concentration	12%
485 Port Settings	BAUD	9600
	Check bit	No parity
	Stop bit	1
	Address of this website	1

6. Oxygen sensor structure

The function of the oxygen sensor is mainly achieved by the following parts:

1) Measuring element

The measuring element integrates heating and measurement functions, outputting different current signals based on changes in oxygen concentration.

2) Gas path

The measuring gas enters from the side of the protective cover, fully contacts the sensing area of the measuring element after passing through the double-layer protective cover, and is then discharged from the top exhaust port.

3) Connector

Connect with the supporting connector, input the heating voltage and output the measurement signal.

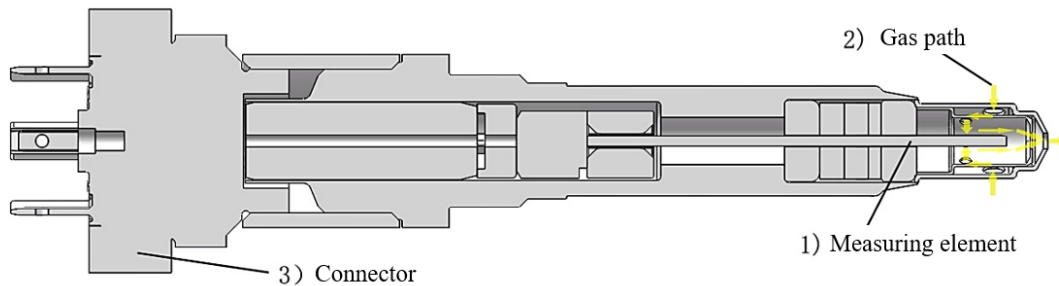

Fig.8 QGY10.0000A8 Oxygen Sensor Structure

7. Installation and connection

7.1 Installation oxygen sensor

For the convenience of installation and use on the chimney, flue gas collector can be optional. AGY20.120A/AGY20.220A flue gas collector has the following functions:

1) Collect flue gas and supply it to the sensor, while extending the position of the oxygen sensor to collect flue gas.

2) Two connection options are provided: threaded fastening and welded fastening, which facilitates the installation of oxygen sensors on the flue.

Fig.9 shows the installation position diagram of the oxygen sensor. The oxygen sensor can be installed slightly tilted in the direction of the airflow, which can accelerate the reaction time when the flow speed is low. At the same time, a slightly tilted angle can allow the condensate to be discharged downstream to avoid damage to the oxygen sensor.

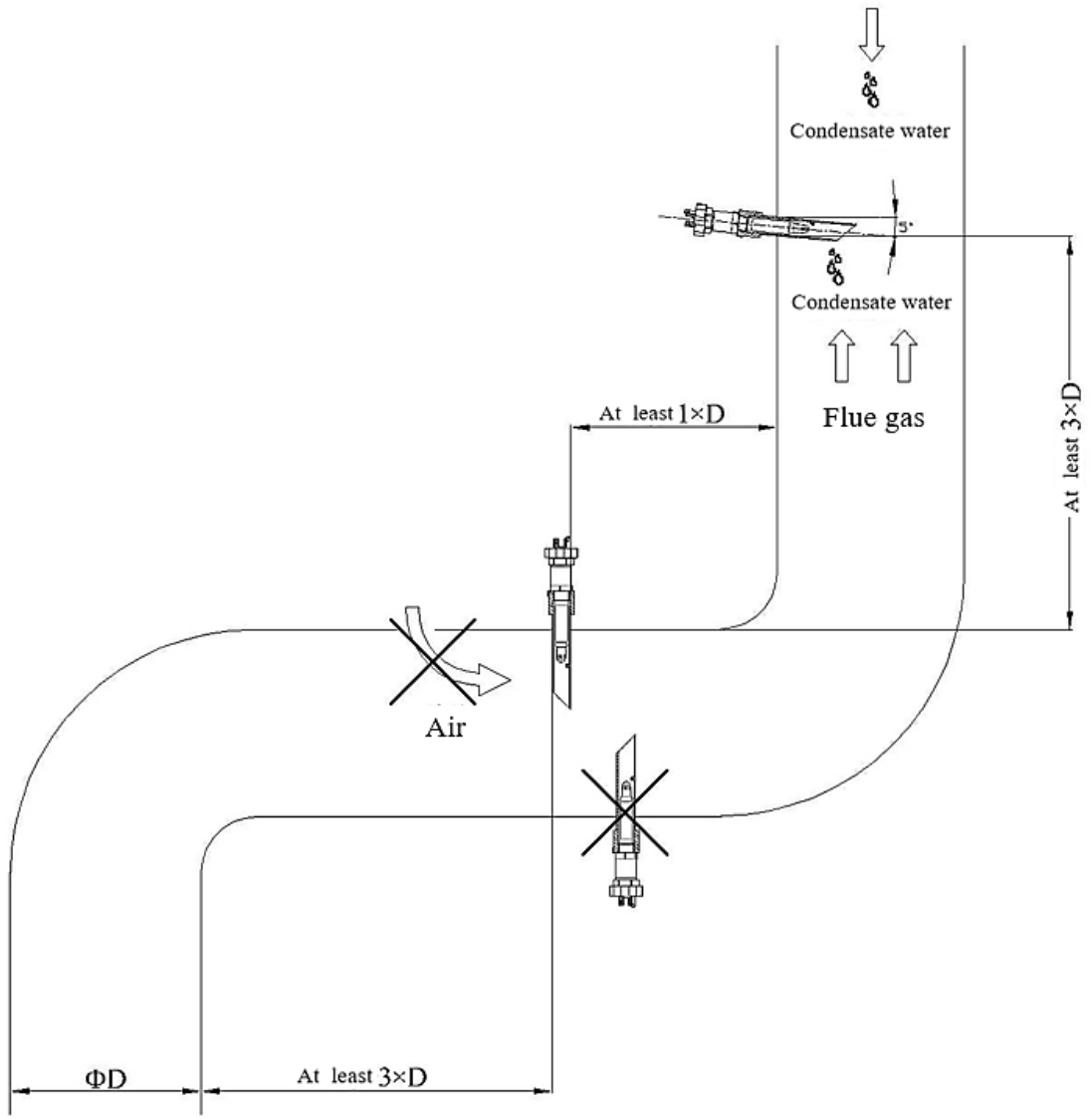

Fig.9 Installation position diagram of QGY10.0000A8 and AGY20.120A/ AGY20.120A

7.2 Controller installation

The controller can be quickly installed on the C45 rail using a back buckle.

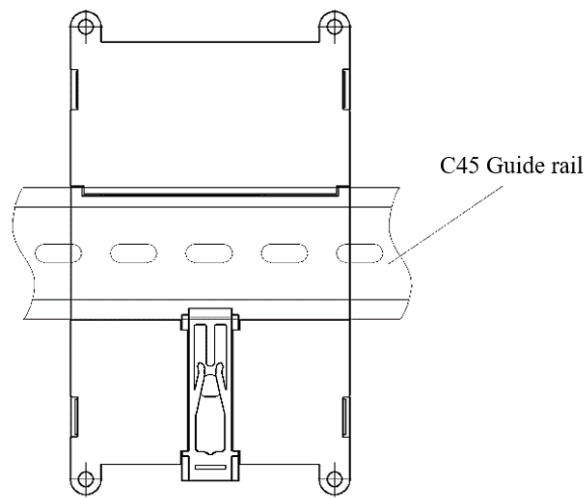

Fig.10 AGY10.000A8 controller installation

7.3 Connect

1) The connection between the sensor and the connecting cable is directly achieved by using a connector to plug in.

The connection between the sensor and the cable adopts a male and female connection, and can be inserted according to the corresponding label.

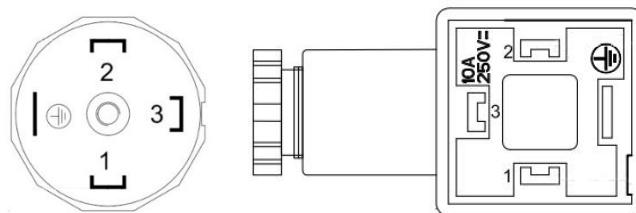

Fig.11 Connector (a) Male (b) Femal

2) Connection of the controller

Controller terminal	Illustrate	Role
+24V	24 VDC Power supply positive	Controller power supply
GND	24 VDC Power supply negative	
H+	Oxygen sensor probe wire 2	Heating power supply
H-	Oxygen sensor probe wire 3	
S+	Oxygen sensor probe wire 1	signal acquisition
S-	Oxygen sensor probe ground wire	
V-	Analog voltage negative	Analog voltage signal output
V+	Analog voltage positive	
I-	Analog current negative	Analog current signal output
I+	Analog current positive	
A+	485 communication positive	485 communication
B-	485 communication negative	
DI	Digital input signal 220 VAC	Start signal
DO	Digital output signal	Passive normally closed contact for alarm, disconnected during alarm

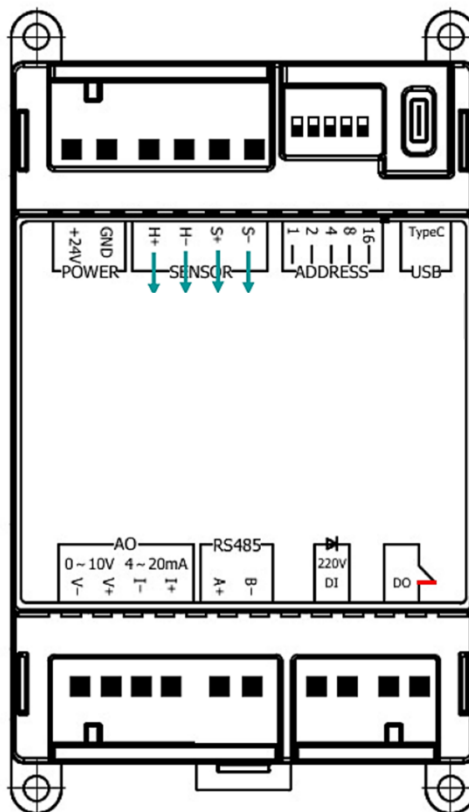

Fig.12 AGY10.000A8 Controller Wiring Diagram

8. Dimension

Unit: mm

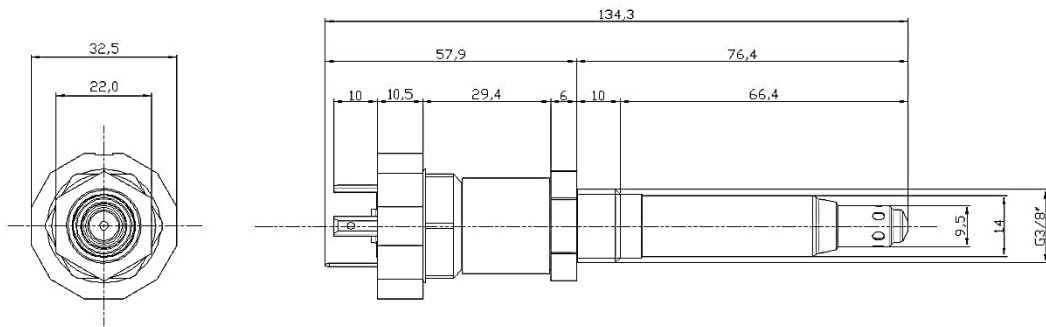

Fig.13 QGY10.0000A8 Dimensional Drawing

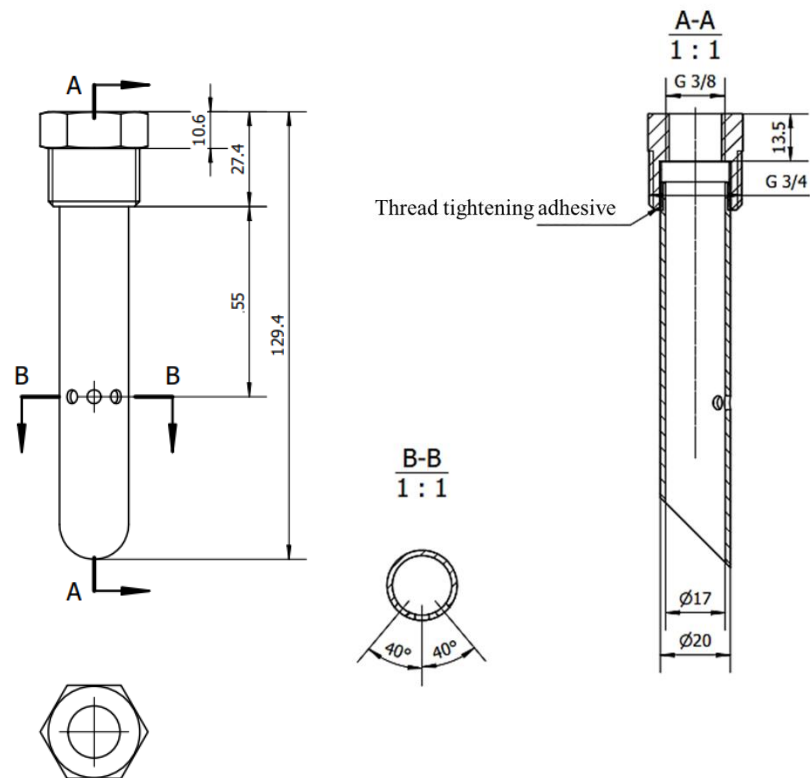

Fig.14 AGY20.120A

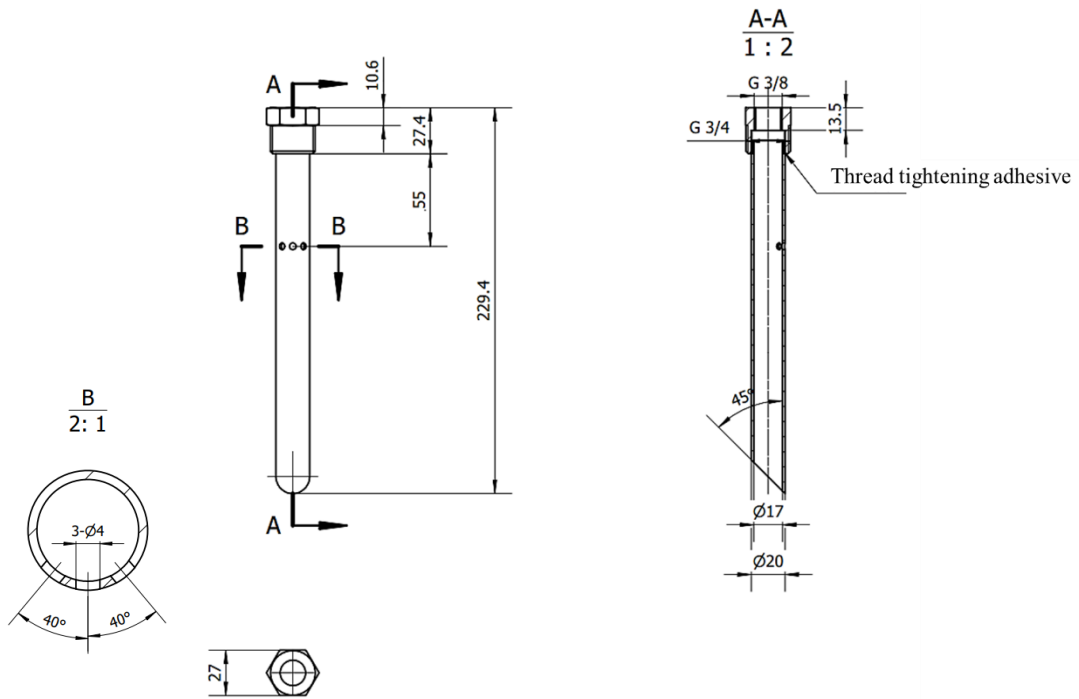

Fig.14 AGY20.220A

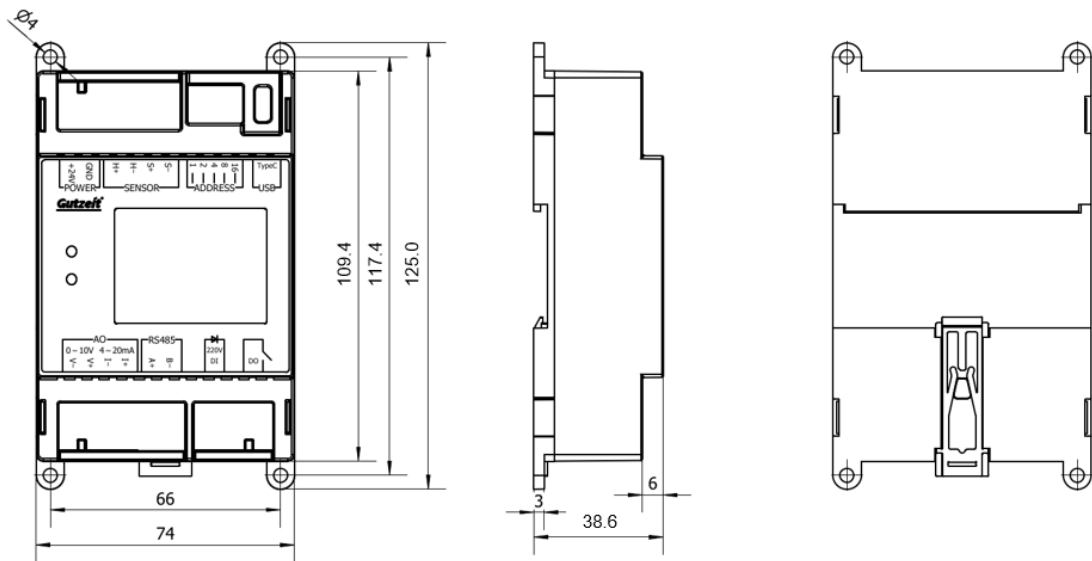

Fig.15 AGY10.000A8